

## System Overview

Last update: Jul 12, 2024

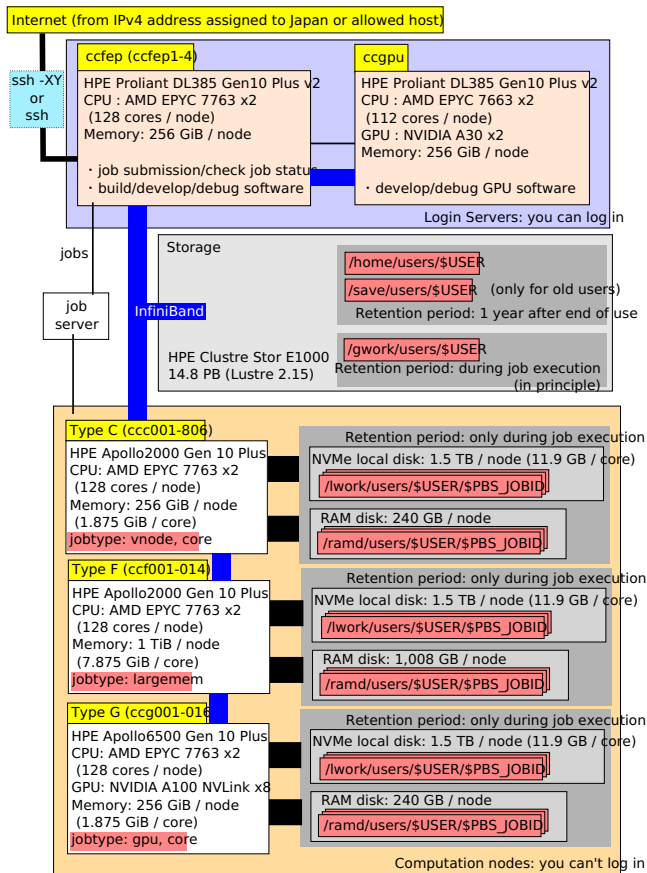

- Only ccfep (ccfep1-4) is accessible from the outside.
- Interactive operation is possible on ccfep (ccfep1-4) and ccgpu.
  - Ccgpu can't access the internet. Download of the files should be done on ccfep.
- Thicker lines in the figure mean broader bandwidth.
- /lwork and /ramd are computation nodes local storage. You can't access them directly from ccfep.
  - It is possible to access them using "remsh" command.
- /ramd is a virtual disk space created on the memory of computation nodes.
  - /ramd usage is also taken into account for the job's memory usage (which is monitored by the system).
- There are no functional differences between /home and /save. The limits value is applied for the sum of /home and /save usage. (/save remains purely for the historical reason.)
- Usage of /tmp, /var/tmp, and /dev/shm are not allowed. If jobs are using those areas, they are removed without warning.